

Welded, Stainless Steel Double-Ended Shear Beam Load Cell

FEATURES

- Rated capacities of 1000 to 75,000 pounds
- Stainless steel, welded seal construction
- Insensitive to side loads and bending moments
- High output—well suited to high deadload/low liveload applications
- Load cells have matched outputs for multi-cell systems
- Integral conduit adaptor
- *Sensorgage™* sealed to IP67 standards
- Factory Mutual System Approved for Classes I, II, III; Divisions 1 and 2; Groups A through G. Also, non-incendive ratings (No barriers!)
- **Optional**
 - Fully hermetically sealed available



65016-TWA



65086



APPLICATIONS

- Hostile environments:
 - Food and beverage processing
 - Chemical and plastics processing
 - Pharmaceutical and biomedical processing
- Tank, bin, and silo weighing
- Batching, blending and mixing systems
- Level and inventory monitoring

DESCRIPTION

65016-0104W is designed to be center-mounted with double-linked loading. This design provides free movement in all horizontal directions virtually eliminating binding or friction points. The double Shear Beam design gives excellent performance for high capacity loading.

65016-0104W is constructed of stainless steel and is designed to work in extremely harsh environments such as chemical and food industry.

OUTLINE DIMENSIONS in inches

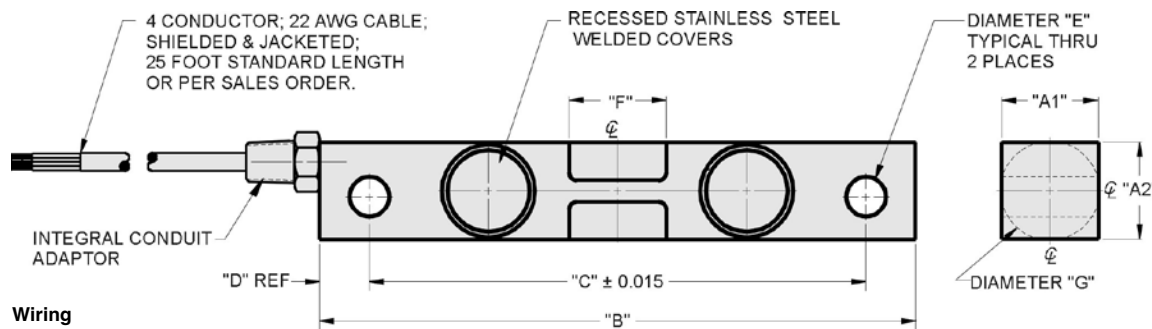

Wiring

| | |
|--------------|-------|
| + Excitation | Red |
| - Excitation | Black |
| + Output | Green |
| - Output | White |

| CAPACITY | A1 | A2 | B | C | D | E | F | G | THREAD |
|----------|------|------|-------|-------|------|------|------|------|-----------|
| 1k-5k | 1.22 | 1.22 | 7.50 | 6.25 | 0.62 | 0.50 | 1.12 | 1.25 | 1/4-18NPT |
| 10k-25k | 1.44 | 1.94 | 8.75 | 7.50 | 0.62 | 0.81 | 1.62 | 1.99 | 1/4-18NPT |
| 35k | 1.44 | 2.44 | 8.75 | 7.50 | 0.62 | 0.81 | 1.62 | 2.50 | 1/4-18NPT |
| 50k-75k | 2.44 | 2.94 | 13.50 | 11.50 | 1.00 | 1.31 | 3.25 | 2.99 | 1/2-14NPT |

Capacities are in pounds.

Welded, Stainless Steel Double-Ended Shear Beam Load Cell

| SPECIFICATIONS | | |
|-----------------------------------|--|---------------------|
| PARAMETER | VALUE | UNIT |
| Rated capacity—R.C. (E_{max}) | 1k, 1.5k, 2.5k, 5k, 10k, 15k, 25k, 35k, 50k, 75k | lbs |
| NTEP/OIML accuracy class | Standard | |
| Maximum no. of intervals (n) | — | |
| Rated output—R.O. | 3.0 | mV/V |
| Rated output tolerance | 0.25 | ±% mV/V |
| Zero balance | 1.0 | ±% FSO |
| Non-linearity | 0.07% | ±% FSO |
| Hysteresis | 0.07% | ±% FSO |
| Non-repeatability | 0.01 | ±% FSO |
| Creep error (20 minutes) | 0.03 | ±% FSO |
| Temperature effect on zero | 0.0015 | ±% FSO/°F |
| Temperature effect on output | 0.0008 | ±% of load/°F |
| Compensated temperature range | 14 to 104 (–10 to 40) | °F (°C) |
| Operating temperature range | 0 to 150 (–18 to 65) | °F (°C) |
| Storage temperature range | –60 to 185 (–50 to 85) | °F (°C) |
| Sideload rejection ratio | 500:1 | |
| Safe sideload | 100 | % of R.C. |
| Maximum safe central overload | 150 | % of R.C. |
| Ultimate central overload | 300 | % of R.C. |
| Excitation, recommended | 15 | VDC or VAC RMS |
| Excitation, maximum | 25 | VDC or VAC RMS |
| Input impedance | 686–714 | Ω |
| Output impedance | 699–707 | Ω |
| Insulation resistance at 50 VDC | >1000 | MΩ |
| Material | Stainless steel | |
| Environmental protection | IP67 IP68 welded seals, glass to metal seal | Standard Special |

FSO—Full Scale Output

All specifications subject to change without notice.